

Gravity Fed Fuel Storage Tanks

www.tectainer.co.uk

WORLDWIDE PATENT PENDING

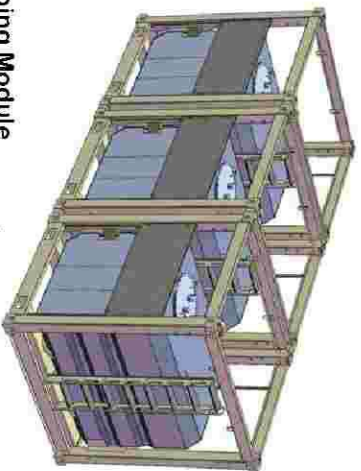

Shipping Module

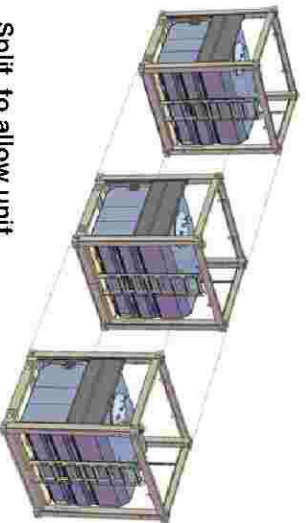

Split to allow unit shipment to various sites

Specification :

Capacity	Loading Height (Discharge Point)	Units/Module	Module Weight	20ft Module Empty
5,020 ltr*	2,025 mm	3	1250 kg	3,750 kg
9,990 ltr	2,050 mm	2	2,000 kg	4,000 kg
Diesel: UN1202				

Standard: Dipstick, 2" fill point (high), 2" Vent "U" Tube, 2" BSP (F) Discharge Connection

Optional Extras: Integral Spill Bund, Hand dispensers, Meters, Hoses and Discharge Shut Off Valves

Compliant Codes and Standards: AS 1692, AS 1657.

Lifting/Transport: Fork or Sling Rated, CSC for shipping as modules.

**Set down
LIFT INNER TANK ONSITE
with "Removable"
CHAIN BLOCKS**

Pin tank in position and install ladder and Handrails on Platform
Instal discharge valve and hose to complete installation

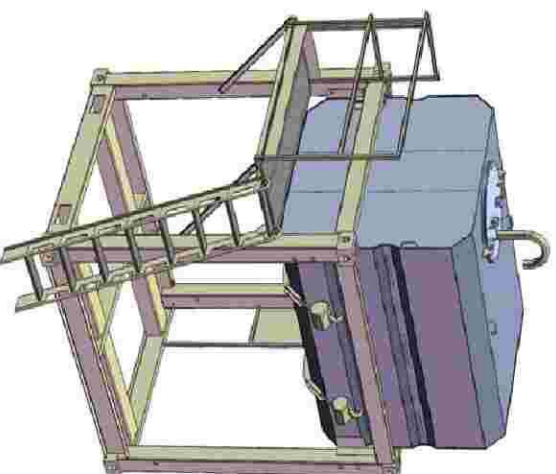

HEAD OFFICE

TEC-Armech UK Limited
Haywards Heath, W. Sussex UK
Ph: +44 (0)1444 230 865
Fax: +44 (0)1444 230 885

JV FACTORY

Armech (Mechanical) Ltd
Jiangsu Province
PR China

WORLDWIDE OFFICES:

- TEC-Armech (Mechanical) Ltd, Shanghai, China
- Armech Mechanical Ltd, Auckland, New Zealand
- Armech Europe SARL, Amecy, France
- Container Options Pty, Sydney, Australia



- Tectainer Products Inc:**
- Bulk Containers
 - 20ft and 40ft Full Opening Side Door Containers
 - Waste-management Containers
 - Open-top, GPs & Flatracks
 - LPG T 50 tanks
 - 27 tonne Bitumen tanks
 - 28,000 ltr Lubricant & Oil Tanks
 - 70 m3 Petrochem Storage Tanks
 - 26,000 ltr tank containers
 - 28,000 ltr Food tanks

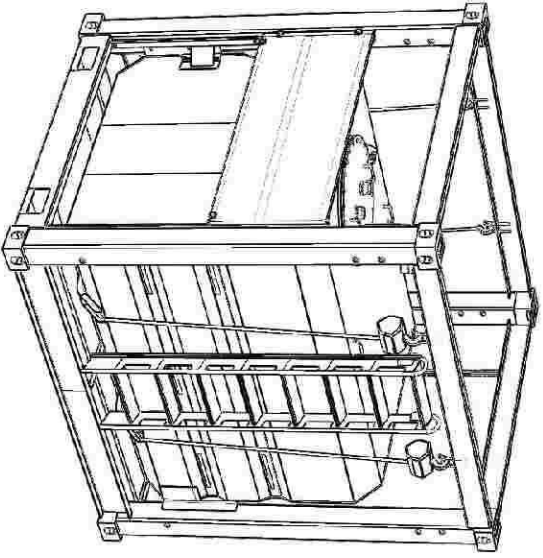

Single Unit

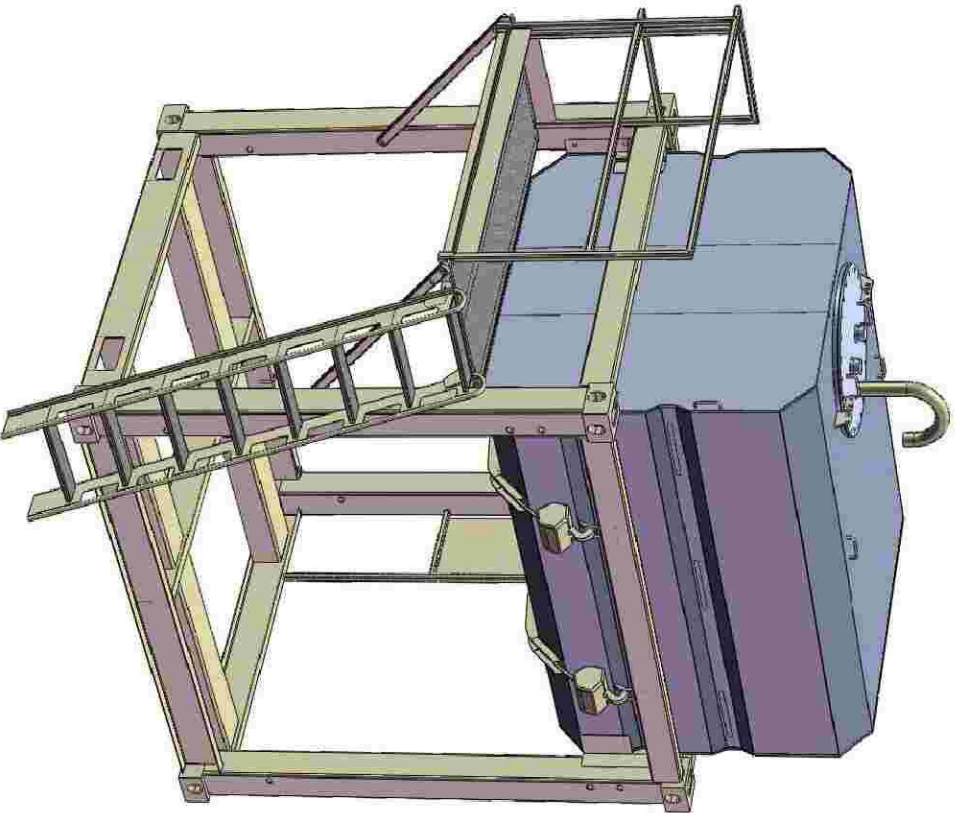

Installed Unit